



AUTOTRACK ESB & REFUSE COLLECTION ROUTE

SCALE @ A1: 1:500
SCALE @ A3: 1:1000

NOTES

1. THIS DRAWING IS TO BE READ IN CONJUNCTION WITH ALL ENGINEERS & ARCHITECTS DRAWINGS. FIGURED DIMENSIONS ONLY (NOT SCALING) TO BE USED. WHERE A CONFLICT OF INFORMATION EXISTS OR IF IN ANY DOUBT - 'ASK'.
2. CONSULTANTS TO BE INFORMED IMMEDIATELY OF ANY DISCREPANCIES BEFORE WORK PROCEEDS.

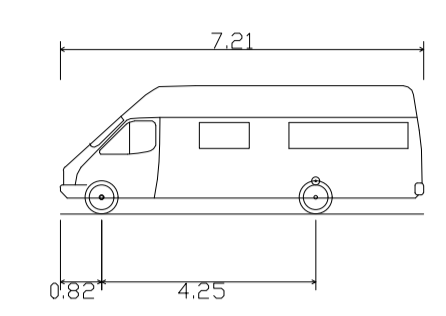

7.5t Panel Van
Overall Length 7.210m
Overall Width 2.192m
Overall Body Height 2.544m
Min Body Ground Clearance 0.316m
Track Width 1.865m
Lock-to-lock time 4.00s
Curb to Curb Turning Radius 7.400m

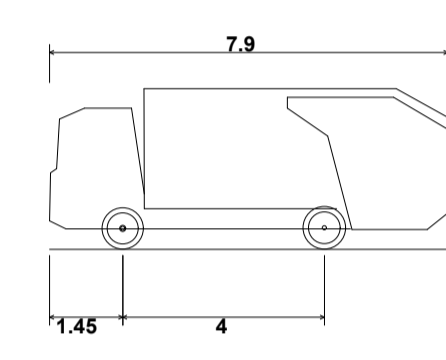

DB32 Refuse Vehicle
Overall Length 7.900m
Overall Width 2.400m
Overall Body Height 3.183m
Min Body Ground Clearance 0.388m
Max Track Width 2.400m
Lock-to-lock time 6.00s
Curb to Curb Turning Radius 9.625m

PL1	12.02.20	ISSUED FOR PLANNING	MC	RM
ISSUE	DATE	DESCRIPTION	DRN	P.E.
			ORIG	P.D.

DRAWING STAGE **PLANNING**

BM Dublin Office: Sandwith House, 52-54 Lower Sandwith Street, Dublin 2, Ireland. Tel: (01) 677 3200 Fax: (01) 677 3164
London Office: 12 Mill Street, London SE1 2AY, United Kingdom. Tel: (0044) 084 5413 2722
 BARRETT MAHONY Consulting Engineers, Civil, Structural, Project Management. E-mail: bmce@bmce.ie Web: www.bmce.ie

The Institution of Structural Engineers ACEI FIDIC

CLIENT **GREENLEAF HOMES LTD.**

PROJECT TITLE MIXED-USE DEVELOPMENT, THE FORMER GALLAHER SITE, AIRTON ROAD, TALLAGHT, D24	BM PROJECT No. 19.136
MODEL REFERENCE	MODEL REV. SUITABILITY

DRAWING TITLE **AUTO TRACK - ESB & REFUSE COLLECTION**

DRAWING No. ARD-BMD-00-XX-DR-C-1041	ISSUE PL1
---	---------------------